



- Selected line of podiatry instruments
- Designed for professionals
- Perfection of workmanship, professionalism in practice

AESCLAP CHIFA®

COSMETIC AND PODIATRY

Features standing for the high quality of Aesculap Chifa nippers

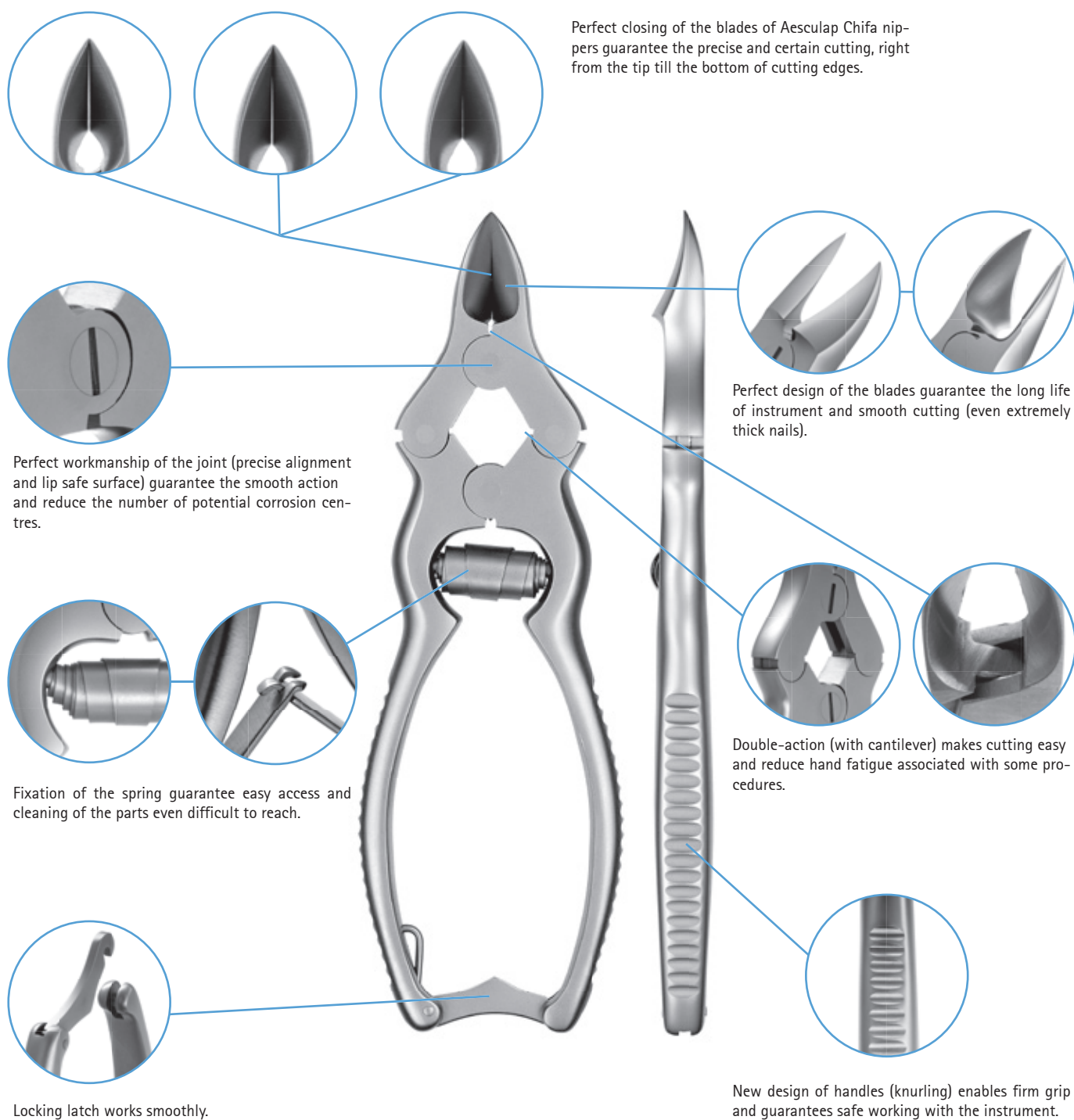

Perfect closing of the blades of Aesculap Chifa nippers guarantee the precise and certain cutting, right from the tip till the bottom of cutting edges.

Perfect design of the blades guarantee the long life of instrument and smooth cutting (even extremely thick nails).

Double-action (with cantilever) makes cutting easy and reduce hand fatigue associated with some procedures.

New design of handles (knurling) enables firm grip and guarantees safe working with the instrument.

Perfect workmanship of the joint (precise alignment and lip safe surface) guarantee the smooth action and reduce the number of potential corrosion centres.

Fixation of the spring guarantee easy access and cleaning of the parts even difficult to reach.

Locking latch works smoothly.



Podiatry is facing significant changes today, with current medical and technological knowledge making treatments more precise. A decisive element in this progress, as well as the increasing improvement of diagnostic possibilities, is the parallel integrated development of podiatric instruments.

With its innovative products, Aesculap Chifa makes a fundamental contribution to this development by expanding and improving the functionality of the products on offer. This allows us to guarantee a wide, modern and specialized range of instruments dedicated to podiatry and cosmetology.

Aesculap Chifa products are created through our close contact with customers from different countries in order to meet the expectations of the podiatric and cosmetic market. Permanent cooperation and exchange of experience with specialists in the field of podiatry and cosmetology plays a decisive role in our work. Aesculap Chifa products have proved their value in daily practice all over the world.

The following offer of Aesculap Chifa services thanks to:

- years of experience and competence in planning and consulting,
- worldwide known excellent product quality,
- customized services to maintain the usability of your instruments,

Pictograms placed next to the instrument have the following meaning:

A)  Overall length of the instrument XXX mm

The length of the tool is measured from the end of the shoulder to the tip of the working part

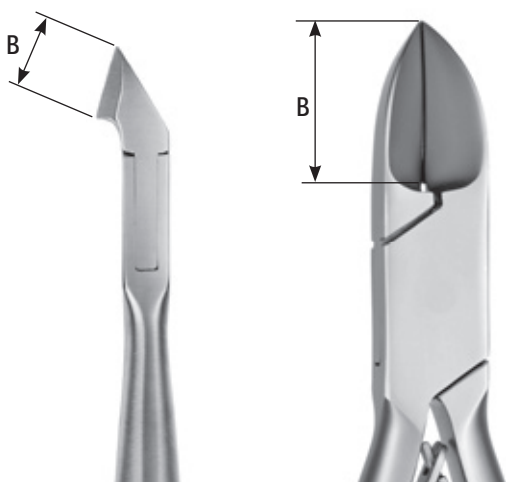

B)  Length of the working part XXX mm

The length of the working part is measured from the beginning to the end of the blade







1/1

MO-135-100-PMS
 100 mm
 5,5 mm
 Double Spring



1/1



MO-135-400-PMS
 100 mm
 4,0 mm
 Double Spring



1/1



1/1

MO-021-110-PMK
 110 mm
 4,0 mm
 Double Spring



MO-460-100-PMS
100 mm
7,5 mm
Single Spring



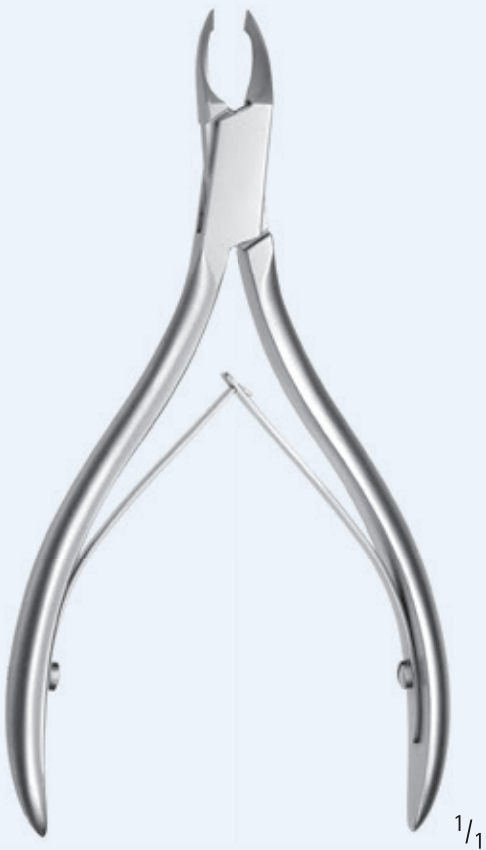

MO-461-110-PMS
110 mm
8,5 mm
Single Spring





MO-016-003-PMK
 110 mm
 3,0 mm
 Double Spring



MO-016-005-PMK
 110 mm
 5,0 mm
 Double Spring



MO-016-110-PMK
 110 mm
 7,0 mm
 Double Spring



1/1



1/1

MO-144-115-PMS
115 mm
10,0 mm
Double Spring



1/1

MO-054-130-PMS
130 mm
9,6 mm
Double Spring

CHIFA



ST-305-140-PMS
140 mm
8,0 mm
Debridement Nipper

1/1

1/1





MO-036-100-PMS
100 mm
11,5 mm
Double Spring
Nail cutter



MO-048-100-PMS
100 mm
10,5 mm
Double Spring
Ingrowing nail cutter



1/1

MO-470-100-PMS
 100 mm
 10,5 mm
 Single Spring



1/1

MO-475-110-PMS
 110 mm
 13,5 mm
 Single Spring
 Ingrowing nail cutter





1/1

MO-476-110-PMS
 110 mm
 7,0 mm
 Single Spring
 Ingrowing nail cutter



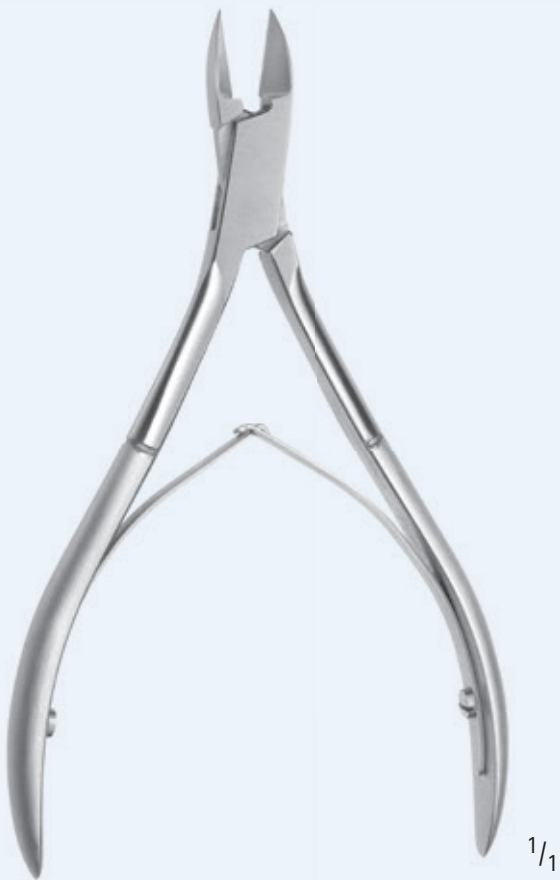

1/1





MO-042-115-PMS
 115 mm
 12,0 mm
 Double Spring
 Nail cutter





MO-047-115-PMS
 115 mm
 12,0 mm
 Double Spring
 Nail cutter



MO-049-115-PMS
 115 mm
 12,8 mm
 Double Spring
 Ingrowing nail cutter



MO-142-115-PMS
 115 mm
 12,0 mm
 Double Spring
 Ingrowing nail cutter

CHIFA



MO-481-115-PMS
115 mm
15,0 mm
Single Spring
Ingrowing nail cutte



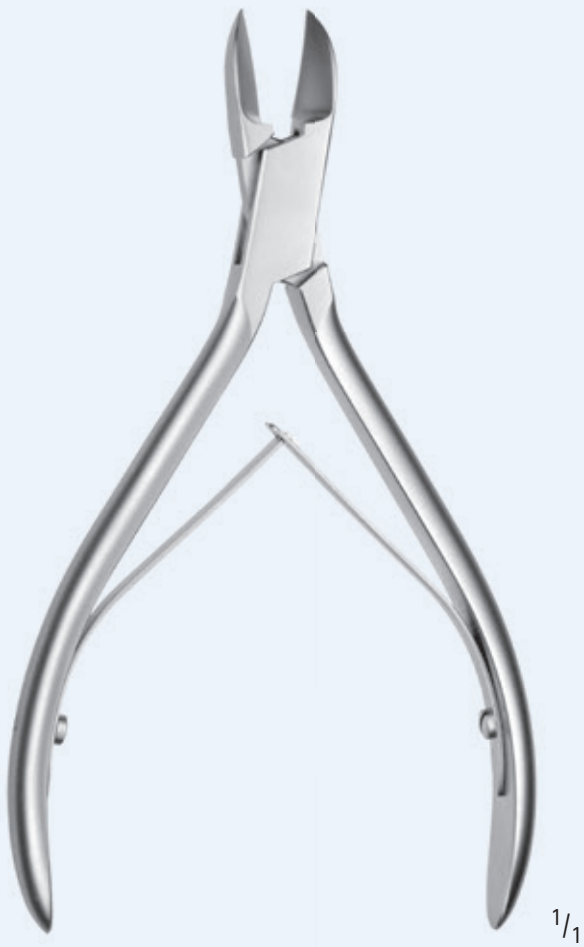

MO-112-120-PMK
120 mm
14,0 mm
Double Spring



MO-129-120-PMK
120 mm
12,5 mm
Double Spring

CHIFA

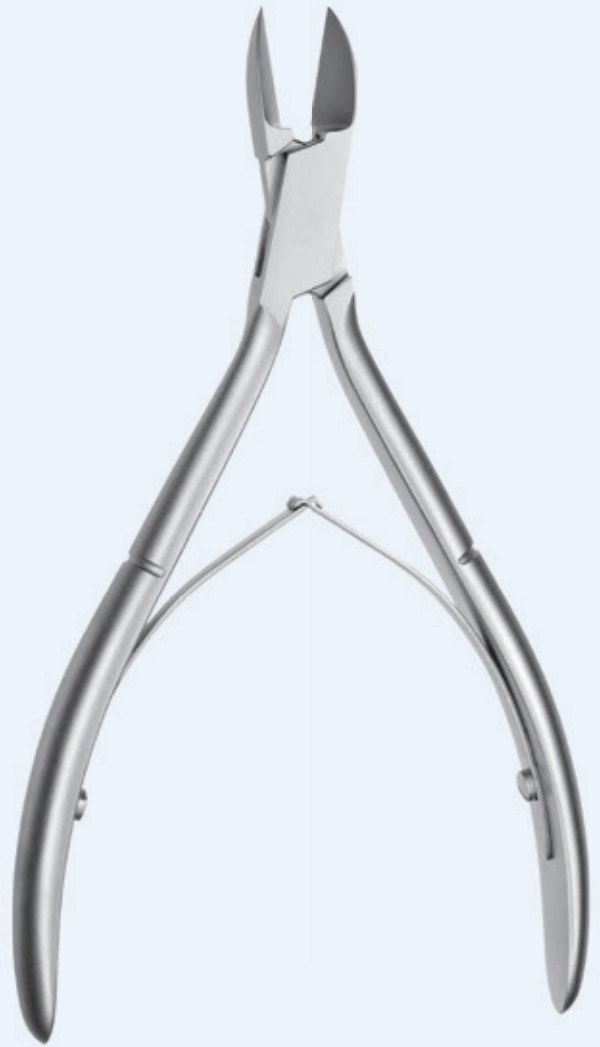

1/1





1/1

MO-037-130-PMS
 130 mm
 15,8 mm / 16,0 mm
 Double Spring



1/1

MO-039-130-PMS
 130 mm
 11,0 mm
 Double Spring



1/1

MO-045-130-PMS
 130 mm
 17,0 mm
 Double Spring
 Ingrowing nail cutter



1/1

MO-153-130-PMS
 130 mm
 13,5 mm
 Double Spring

CHIFA



MO-479-130-PMS
130 mm
15,0 mm
Single Spring

1/1

1/1

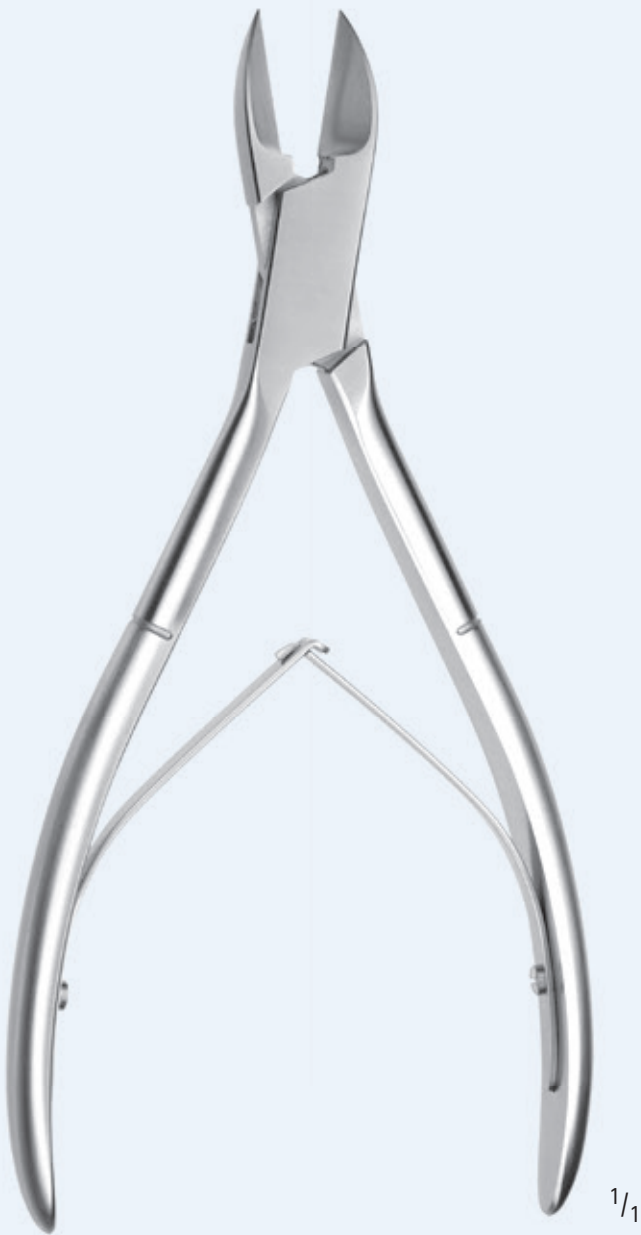

1/1



1/1

MO-038-160-PMS
 160 mm
 19,0 mm
 Double Spring



1/1

MO-041-160-PMS
 160 mm
 18,0 mm
 Double Spring



1/1

MO-141-160-PMS
 160 mm
 19,5 mm
 Double Spring
 Ingrowing nail cutter



MO-080-150-PMS
 150 mm
 17,0 mm
 Double Spring



MO-480-150-PMS
 150 mm
 17,5 mm
 Double Spring



MO-180-050-PMS
 150 mm
 18,5 mm
 Double Spring



MO-013-140-PMK
140 mm
18,0 mm
Double Spring



MO-014-140-PMS
140 mm
18,0 mm
Double Spring



1/1



1/1

MO-034-140-PMS
140 mm
12,5 mm
Double Spring



1/1

MO-133-140-PMS
140 mm
23,5 mm
Double Spring



MO-028-140-PMS
 140 mm
 17,0 mm
 Double Spring



MO-027-140-PMK
 140 mm
 20,5 mm
 Double Spring



MO-017-140-PMS
 140 mm
 20,5 mm
 Double Spring



1/1



1/1

MO-211-135-PMS
135 mm
16,0 mm
Double Spring



1/1

MO-210-135-PMS
135 mm
18,5 mm
Double Spring



1/1



1/1

MO-011-135-PMS
 135 mm
 20,5 mm
 Single Spring



1/1

MO-223-130-PMS
 130 mm
 18,5 mm
 Single Spring

CHIFA



1/1



1/1

MO-243-135-PMS

135 mm

20,5 mm

Barrel Spring



1/1

MO-241-120-PMS

120 mm

16,0 mm



Barrel Spring



1/1



1/1

MO-023-155-PMS
 155 mm
 21,0 mm
 Barrel Spring

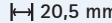

1/1

MO-024-155-XPMS
 155 mm
 20,5 mm
 Barrel Spring

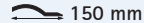
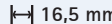

1/1

MO-214-150-PMS
 150 mm
 16,5 mm
 Barrel Spring



CHIFA





MO-224-155-PMK
155 mm
20,5 mm
Double Spring





MO-023-120-PMS
 120 mm
 13,5 mm
 Barrel Spring



MO-024-120-XPMS
 120 mm
 14,0 mm
 Barrel Spring

CHIFA

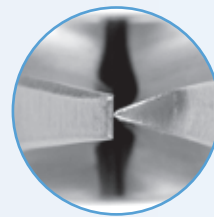
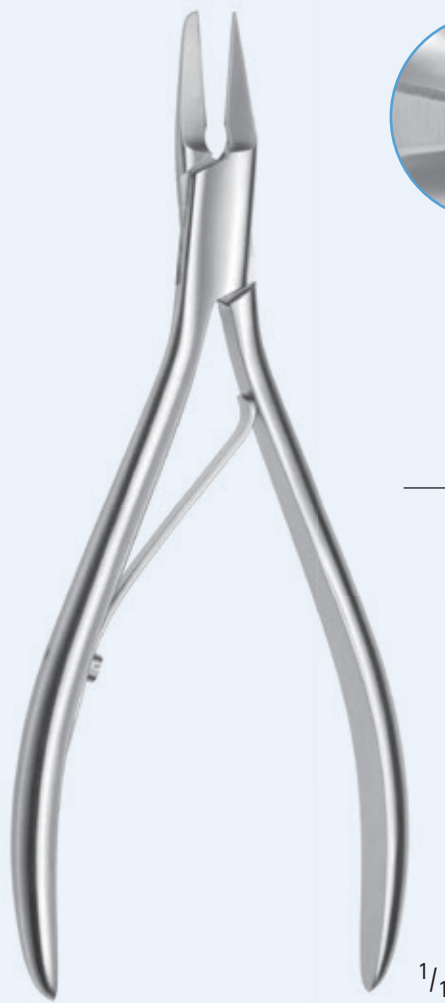

MO-266-130-PMS
130 mm
15,0 mm
Single Spring



NAIL SPLITTING FORCEPS



1/1

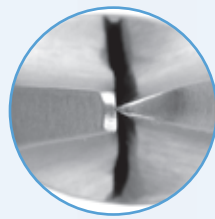

1/1

MO-046-130-PMS
 130 mm
 14,0 mm
 Double Spring

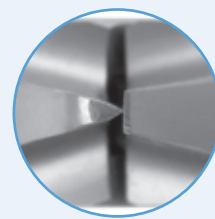

1/1

MO-131-135-PMK
 135 mm
 15,0 mm
 Double Spring

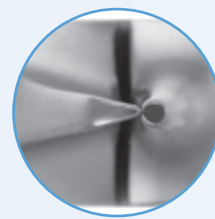

1/1

MO-031-135-PMK
 135 mm
 15,0 mm
 Double Spring

CHIFA



MO-015-085-ZMS

 85 mm

 16,0 mm

Blunt tips / Curved blades
For children



MO-003-090-ZMS
 90 mm
 18,0 mm
 Sharp tips / Curved blades



MO-004-090-ZMS
 90 mm
 16,0 mm
 Sharp tips / Curved blades

CHIFA



1/1

MO-010-095-PMK

95 mm

26,0 mm

Sharp tips / Straight blades



1/1



1/1

MO-010-095-ZMK

95 mm

26,0 mm

Sharp tips / Curved blades



1/1

MO-010-105-ZMK

105 mm

31,0 mm

Sharp tips / Curved blades



NO-050-110-PMK
 110 mm
 29,0 mm
 Sharp tips / Straight blades



NO-051-110-PMK
 110 mm
 25,0 mm
 Sharp tips / Straight blades



NO-050-110-ZMK
 110 mm
 27,5 mm
 Sharp tips / Curved blades



NO-051-110-ZMK
 110 mm
 19,5 mm
 Sharp tips / Curved blades



1/1



PO-066-005-PMK
120 mm
Blunt tips / Straight



1/1

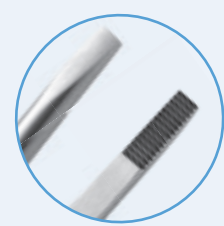

PO-080-090-PMK
90 mm
Straight edge

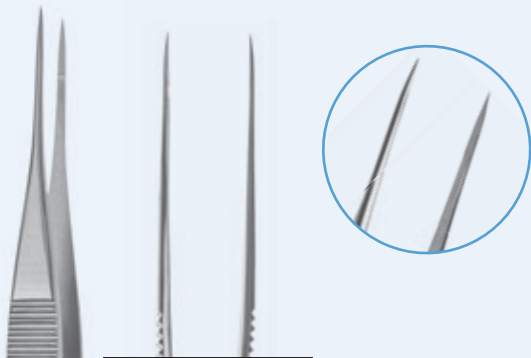

PO-024-002-PMK
 125 mm
 Blunt tips / Straight



PO-027-001-PMK
 120 mm
 Sharp tips / Straight

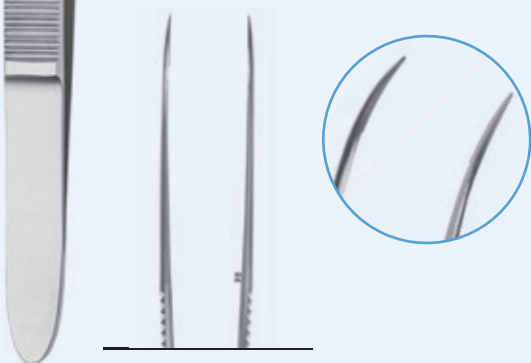

PO-024-002-ZMK
 125 mm
 Blunt tips / Curved



1/1

TH-095-003-PMK
120 mm

1/1



1/1

TH-195-003-PMK
120 mm
With scale

1/1

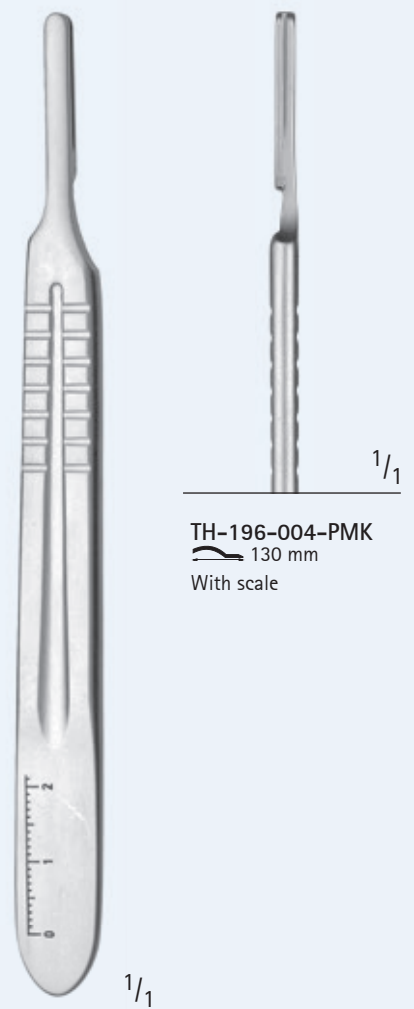
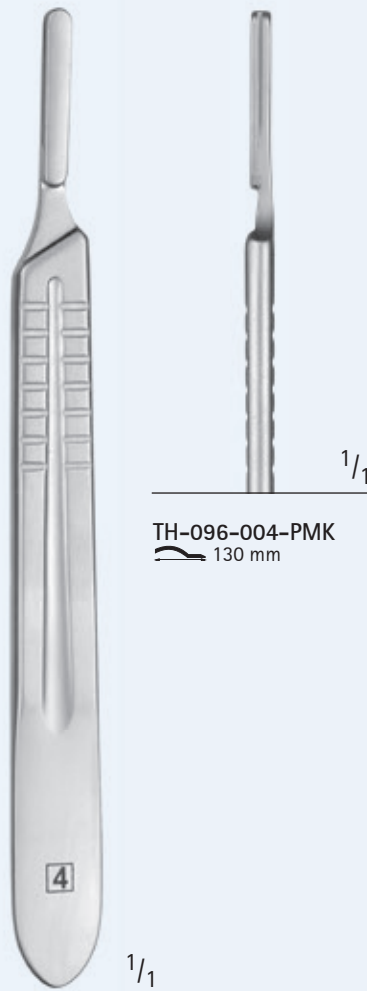

CHIFA



1/1

TH-097-003-PMK
160 mm

1/1



1/1

TH-197-003-PMK
160 mm
With scale

1/1



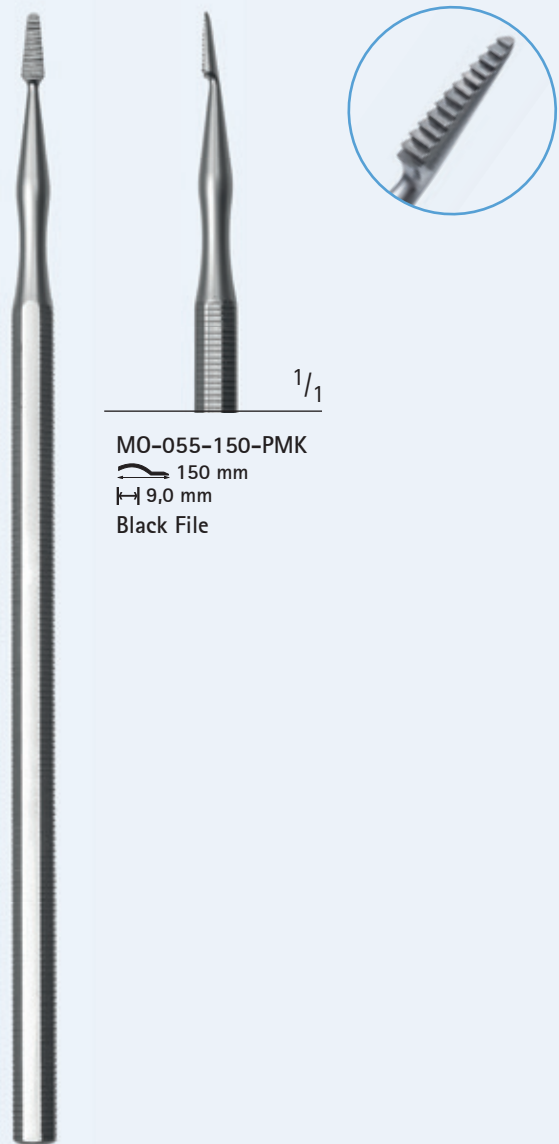



Cutters	Springs set
MO-016-110-PMK	MO-016-110-80
MO-112-120-PMK	
MO-045-130-PMS	MO-144-115-80
MO-144-115-PMS	
MO-047-115-PMS	
MO-036-100-PMS	MO-036-903-80
MO-135-100-PMS	
MO-135-400-PMS	
MO-037-130-PMS	MO-037-130-80
MO-013-140-PMS	MO-013-140-80
MO-027-140-PMS	MO-027-140-80

Cutters	Springs and screw sets
MO-016-110-PMK	MO-016-110-90
MO-112-120-PMK	
MO-017-140-PMS	MO-210-135-90
MO-039-130-PMS	MO-039-130-90
MO-045-130-PMS	MO-144-115-90
MO-144-115-PMS	
MO-047-115-PMS	
MO-048-100-PMS	MO-048-100-90
MO-049-115-PMS	
MO-054-130-PMS	MO-054-130-90
MO-036-100-PMS	MO-036-100-90
MO-135-100-PMS	
MO-135-400-PMS	
MO-141-160-PMS	MO-141-160-90
MO-481-115-PMS	MO-481-115-90
MO-037-130-PMS	MO-037-130-90
MO-153-130-PMS	MO-153-130-90
MO-133-140-PMS	MO-133-140-90
MO-210-135-PMS	MO-210-135-90

Technical Service

Professional repair of podiatry instruments

Aesculap Chifa provides professional repair of podiatry instruments.

The main advantage of our service is that the repair processes include identical technological processes as the production of new instruments like: grinding, polishing, sharpening, elimination of corrosion spots, etching.)

If your instruments are not working properly, got blunt or are distorted, please send them to us.

Thanks to our experience in instruments' manufacturing we are able to refurbish the instruments for around 30 % of the value of a new nipper.

The cooperation with Aesculap Chifa provides you the following benefits:

- instruments undergo the same production processes as production of a new instruments
- all instruments are tested on the same testing materials as new instruments
- the functionality of instruments is identical like new instruments
- You get your instruments in new-like, optimal state, allowing further safe use
- 6-month warranty for the regenerated instruments

Please familiarize yourself with our detailed offer at our web page www.chifa-oem.pl

ALPHABETICAL INDEX



MO-003-090-ZMS	31	MO-046-130-PMS	29	MO-475-110-PMS	10
MO-004-090-ZMS	31	MO-047-115-PMS	11	MO-476-110-PMS	10
MO-010-095-PMK	32	MO-048-100-PMS	9	MO-479-130-PMS	16
MO-010-095-ZMK	32	MO-049-115-PMS	11	MO-480-150-PMS	18
MO-010-105-ZMK	32	MO-054-130-PMS	7	MO-481-115-PMS	12
MO-011-135-PMS	23	MO-055-150-PMK	39	NO-050-110-PMK	33
MO-013-140-PMK	19	MO-080-150-PMS	18	NO-050-110-ZMK	33
MO-014-140-PMS	19	MO-112-120-PMK	13	NO-051-110-PMK	33
MO-015-085-ZMS	30	MO-129-120-PMK	13	NO-051-110-ZMK	33
MO-016-003-PMK	6	MO-131-135-PMK	29	PO-024-002-PMK	35
MO-016-005-PMK	6	MO-133-140-PMS	20	PO-024-002-ZMK	35
MO-016-110-PMK	6	MO-135-100-PMS	4	PO-027-001-PMK	35
MO-017-140-PMS	21	MO-135-400-PMS	4	PO-066-005-PMK	34
MO-021-110-PMK	4	MO-141-160-PMS	17	PO-080-090-PMK	34
MO-023-120-PMS	27	MO-142-115-PMS	11	ST-305-140-PMS	8
MO-023-155-PMS	25	MO-144-115-PMS	7	TH-095-003-PMK	36
MO-024-120-XPMS	27	MO-153-130-PMS	15	TH-096-004-PMK	37
MO-024-155-XPMS	25	MO-180-050-PMS	18	TH-097-003-PMK	38
MO-027-140-PMK	21	MO-210-135-PMS	22	TH-195-003-PMK	36
MO-028-140-PMS	21	MO-211-135-PMS	22	TH-196-004-PMK	37
MO-031-135-PMK	29	MO-214-150-PMS	25	TH-197-003-PMK	38
MO-034-140-PMS	20	MO-223-130-PMS	23	Springs sets	40
MO-036-100-PMS	9	MO-224-155-PMK	26	Springs and screws	40
MO-037-130-PMS	15	MO-241-120-PMS	24		
MO-038-160-PMS	17	MO-243-135-PMS	24		
MO-039-130-PMS	15	MO-266-130-PMS	28		
MO-041-160-PMS	17	MO-460-100-PMS	5		
MO-042-115-PMS	11	MO-461-110-PMS	5		
MO-045-130-PMS	15	MO-470-100-PMS	10		

CATEGORICAL INDEX

Nail skin cutters					
MO-135-100-PMS	4	MO-017-140-PMS	21	MO-003-090-ZMS	31
MO-135-400-PMS	4	MO-027-140-PMK	21	MO-004-090-ZMS	31
MO-021-110-PMK	4	MO-028-140-PMS	21	MO-010-095-PMK	32
MO-460-100-PMS	5	MO-210-135-PMS	22	MO-010-095-ZMK	32
MO-461-110-PMS	5	MO-211-135-PMS	22	MO-010-105-ZMK	32
MO-016-003-PMK	6	MO-011-135-PMS	23	NO-050-110-PMK	33
MO-016-005-PMK	6	MO-223-130-PMS	23	NO-051-110-PMK	33
MO-016-110-PMK	6	MO-243-135-PMS	24	NO-050-110-ZMK	33
MO-054-130-PMS	7	MO-241-120-PMS	24	NO-051-110-ZMK	33
MO-144-115-PMS	7	MO-023-155-PMS	25	Tweezers	
ST-305-140-PMS	8	MO-024-155-XPMS	25	PO-066-005-PMK	34
Nail cutters		MO-214-150-PMS	25	PO-080-090-PMK	34
MO-036-100-PMS	9	MO-224-155-PMK	26	PO-024-002-PMK	35
MO-470-100-PMS	10	MO-023-120-PMS	27	PO-024-002-ZMK	35
MO-042-115-PMS	11	MO-024-120-XPMS	27	PO-027-001-PMK	35
MO-047-115-PMS	11	Ingrowing nail cutters		Scalpel holders	
MO-112-120-PMK	13	MO-048-100-PMS	9	TH-095-003-PMK	36
MO-129-120-PMK	13	MO-475-110-PMS	10	TH-195-003-PMK	36
MO-037-130-PMS	15	MO-476-110-PMS	10	TH-096-004-PMK	37
MO-039-130-PMS	15	MO-049-115-PMS	11	TH-196-004-PMK	37
MO-153-130-PMS	15	MO-142-115-PMS	11	TH-097-003-PMK	38
MO-479-130-PMS	16	MO-481-115-PMS	12	TH-197-003-PMK	38
MO-038-160-PMS	17	MO-045-130-PMS	15	Nail file	
MO-041-160-PMS	17	MO-141-160-PMS	17	MO-055-150-PMK	39
MO-480-150-PMS	18	Nail splitting forceps		Springs sets	
MO-080-150-PMS	18	MO-266-130-PMS	28		40
MO-180-050-PMS	18	MO-046-130-PMS	29	Springs and screws sets	
MO-013-140-PMK	19	MO-131-135-PMK	29		40
MO-014-140-PMS	19	MO-031-135-PMK	29		
MO-034-140-PMS	20	Nail scissors			
MO-133-140-PMS	20	MO-015-085-ZMS	30		

AESULAP CHIFA Sp. z o.o. Tysiąclecia 14. 64-300-Nowy Tomyśl, Poland

tel. +48 61 44 20 261, fax. +48 61 44 20 260

eksport_chifa@bbraun.com | www.chifa-oem.pl