

Chifa - Bone surgical instruments



Bone Rongeurs



Chifa—a manufacturer of over 3.000 models of surgical instruments meeting the world quality parameters, dedicated for use in general surgery, bone surgery, microsurgery, dentistry, and veterinary, as well as a number of ideapplication non-medical instruments.

This catalogue presents a full range of bone surgical instruments—Rongeurs.

Today CHIFA employs about 1.000 people in its fully featured facility located in Nowy Tomyśl, Poland.

The highest quality of the manufactured products is guaranteed thanks to the over 50-year-long experience in production of surgical instruments, as well as to the newest production technologies, and careful quality control. In 1996 was introduced the Quality Assurance System, matching the standards of both ISO 9001 and EN 46001. Today CHIFA is legalized to put the CE mark together with its own identification on each product it manufactures. The leading and the most demanding Company, namely TUV Product Service GmbH, Germany, certifies CHIFA in this field.

CHIFA was founded in 1945 to satisfy the needs of the Polish health care in the range of the medical instruments. The company rapidly formed a sound base on which to expand by recruiting qualified technicians and experts. Also, in order to do that, a specialized department dedicated to the R & D of new products has been formed. As a result, in 1953, CHIFA initiated export sales, which grew rapidly over the next twenty years.

A significant increase in export sales occurred after the political and economic changes in Poland, which took place in 1989.

Today, more than 92% of the CHIFA's production is exported to over 40 countries around the world. The key export markets are: Japan, Germany, USA. Other prominent markets include The United Kingdom, France, Italy, Spain, Korea, Mexico, Brazil, Australia, and many other countries.

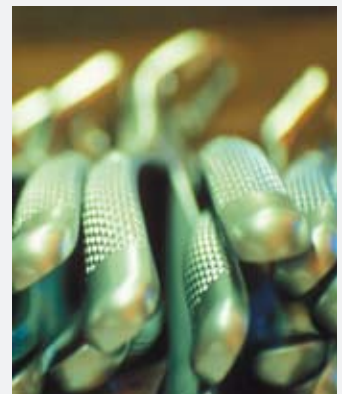





SURGICAL INSTRUMENTS TREATMENT RULES

All instruments presented in the catalogue are made of stainless steel, unless otherwise specified. The drawings presented in the catalogue are made to a 1/1 scale and the photographs are made to a 1/2 scale. If the photographs are made to a different scale it will be specified next to the photograph.

1. Ordering Information

Surgical instruments manufactured by CHIFA may be ordered via our authorized representatives or directly by CHIFA. To get in touch with CHIFA Representative responsible for your region or Customer Service department please phone +48 61 4420270.

CHIFA surgical instruments are also available in 70 countries worldwide. To get in touch with a CHIFA Representative responsible for your country please phone: +48 61 4420260. Upon ordering, in order to avoid mistakes, please state the product code and description. Should you have any problems concerning CHIFA products or services please advise your representative of the problem or contact CHIFA company directly at the following number: +48 61 4420100.

If you need to return the instruments please contact the representative responsible for your region or the company directly.

2. New Instruments

Newly purchased instruments must be cleaned, lubricated and sterilized in an autoclave directly before use.

3. Customized Instruments

CHIFA may design and manufacture instruments adapted to individual needs of doctors and patients. We have the necessary experience and knowledge as well as a quality system compliant with ISO 9001 and EN 46001 standards, which assure that customized instruments meet the requirements of our clients perfectly.

Our employees will cooperate with you to match the products to your specific needs. Further information on this issue is available from CHIFA at the following phone numbers: +48 61 4420100 or +48 61 4420260.

4. Surface Maintenance

CHIFA surgical instruments are crafted from the finest German stainless steel resistant to corrosion. The steel has been specially selected to meet various requirements in the field of cutting, constricting, retracting and chiseling.

A characteristic property of this type of steel is that it forms passive layers on the instrument's surface, providing protection against corrosion. These layers act as invisible patina and cause that with each application and exposure to air the instruments become more and more corrosion resistant.

Although the manufacturing process incorporates all treatments aimed at providing resistance to corrosion, the real key to the instruments' long service life lies in proper maintenance. It is the users' responsibility to take proper care of the instruments. In a sense, the term „stainless steel" is incorrect and thus cannot be treated literally. If we mistreat stainless steel it may lose its color and start to corrode abridging the instruments' service life or rendering it useless. Below we present guidelines for proper treatment of surgical instruments.

4a. Transport and Storage

All the instruments should be treated with due care during transport, cleaning, maintenance, sterilization and storage. This is especially important with regard to blades, fine tips and other delicate elements. Surgical instruments undergo corrosion and their performance is defective when they come into contact with aggressive substances such as acids or aggressive detergents.

After drying the instruments completely, place them in a dry and clean place. Do not store them in places where chemicals may emit corrosive fumes or where fluctuating temperature of humidity may cause vapor to conden-



on the instruments. Instruments should be stored in dry, clean and humidity-free areas. Instruments should be stored separately in their own primary packaging. If the instruments are kept in a drawer, their tips should be protected by means of cloth, gauze or a special tube.

4b. Proper Use

Instruments are designed for a specific purpose and should be used accordingly. Even the strongest instrument may be damaged if misused, e.g., when nail pliers are used for cutting wire. Using instruments for purposes or in a way differing from that resulting from the name and application may cause damage to the instruments or defects which may lead to serious injury or even death of a patient.

Such use of an instrument causes that the warranty given by CHIFA becomes void.

4c. Cleaning

● *Water and stainless steel*

Ordinary tap water contains minerals which may cause decoloring and corrosion. Therefore, we recommend the use of distilled water for cleaning, disinfecting, sterilizing and rinsing instruments. In order to avoid corrosion use a cleaning solution with a near-neutral pH (7).

● *Ultrasound cleaning*

The ultrasound method is the most effective and efficient method for cleaning surgical instruments. In order to raise the effectiveness first clean the instruments off any visible residue before placing them in the ultrasonic cleaner. Moreover, we recommend following the rules specified below:

- Do not mix in one cycle instruments made of stainless steel and instruments made of carbon steel covered with a galvanizing layer.
- Open all the instruments so that locks and latches are accessible.
- Avoid stacking instruments one over the other during loading.
- Remove and rinse the instruments immediately after cycle end.
- Dry the instruments immediately after rinsing and leave them in open air to dry completely.
- Lubricate all movable parts.

ATTENTION- After ultrasound cleaning perform a careful inspection of the instruments in terms of potential loosening of particular parts, e.g., loose screws.

● *Manual cleaning and soaking*

If ultrasound-cleaning equipment is not available, the instruments should be cleaned very carefully. Special attention should be paid to cleaning locks, teeth, hinges and other difficult to access areas. For cleaning use nylon (not steel) brushes and warm (not hot) cleaning solutions. Follow the manufacturer's instructions while preparing solutions. Change the solution in accordance with the manufacturer's recommendation.

Instruments should be treated with utmost care in order not to damage their delicate tips and mechanisms. If the instruments came into contact with blood, tissue, physiological saline or other foreign substances, they should be rinsed with warm (not hot) water before the substance dries up on the instruments. After rinsing, dip the instrument in a cleaning and disinfecting solution.

The best effects are achieved by cleaning and rinsing the instruments immediately after each application. Delayed cleaning may result in particles sticking to the instruments or secretions drying up making them resistant to cleaning, and in the future difficult or even impossible to sterilize.

Since many chemical compounds and substances have a strong corrosive effect on stainless steel, instruments should be immediately rinsed and dried if they were exposed to any potentially hazardous substances.



4d. Inspection

Before each application check and test the instruments. Visible defects, cracks, deformed elements or blunt blades indicate that the instruments require repair and must not be used.

Inspection of instruments:

The best time to check the condition of the instruments is after cleaning and lubrication, after they have cooled down.

The application of defective instruments is strictly forbidden. Never attempt to repair the instruments on your own. Servicing and repair work should be carried out exclusively by trained and qualified employees of our authorized service point. Questions concerning repair should be reported to the manufacturer.

Upon inspection pay attention to:

- Performance- pliers, forceps and scissors must cut smoothly and close properly. Needle handles and clips must close properly and their tips must meet.
- Surfaces- inspect the surface carefully in search for traces of decoloring, cracks or other irregularities. The most common reasons for decoloring and corrosion include:
 - Improper cleaning
 - Simultaneous sterilization of instruments made of stainless steel and carbon steel covered with a chrome layer.
 - Water contamination.
 - Inadequate or improper preparation and use of improper cleaning, disinfection or maintenance agents.
 - Failure to observe operating procedures for cleaning and sterilization.

4e. Lubrication

After cleaning the instruments and prior to sterilization in an autoclave lubricate all movable parts. If the instruments are to be sterilized in vapor, the use of an authorized water-soluble lubricant is recommended (in accordance with the instructions attached to the instrument).

5. Sterilization

Sterilization guidelines compliant with the relevant national regulations should be adhered to. Proper parameters regarding the sterilization time, temperature and pressure should be taken from the instructions provided by the manufacturer of the sterilization equipment.

● *Lubrication and autoclave sterilization*

All instruments must be properly cleaned before being placed in the autoclave. Next, their movable parts such as locks or hinges should be lubricated thoroughly. Use lubricants recommended in the user's manual enclosed with each CHIFA instrument. Do not use industrial oils. Always sterilize equipment in their open position. It is recommended to wrap the instruments in a cloth and then place them in the container or to spread the cloth on the bottom of the container so that it absorbs humidity. The cloth should be of neutral pH (7) and free of any detergent residue. Before application, leave the instrument to cool down freely to room temperature. Follow the manufacturer's instructions on vapor autoclave operation and loading. Vapor must have free access to all instrument surfaces including inner surfaces, channels and cables.

6. Regeneration Program

Within this program we will repair and renovate CHIFA instruments and other high quality instruments. Our services also include precise sharpening, adjustments, tip replacement and lubrication.

The majority of services are performed within 14 working days. In case of emergency please contact us in advance to arrange a rush service.

Within this program and in line with CHIFA warranty each faulty CHIFA instrument covered by the warranty will be replaced or repaired free of charge. All our service repairs are subject to quality tests and assure correct performance of the functions assigned to specific instruments. You may receive more detailed information about our



Service Repair Program and a current price list by calling +48 61 4420100 or +48 61 4420260.

CHIFA Instruments Treatment Checklist

1. Rinse and soak contaminated instruments immediately after use. Clean thoroughly before sterilizing in an autoclave.
2. During autoclave sterilization instruments should be open.
3. Do not stack the instruments or allow them to come into contact with one another.
4. Follow the instructions provided by equipment and solution manufacturers.
5. Store the instruments properly lubricated.
6. Perform regular instrument inspections.
7. In case of any problems encountered at any stage of the maintenance process contact the CHIFA representative.

Warranty

*CHIFA warrants that all its medical instruments are free from defects in material or workmanship. For standard instruments CHIFA grants a 1 year warranty and for hard-insert instruments- 2 years. This warranty supersedes all other warranties, express or implied, including warranty for fitness for a particular use or purpose. The warranty does not apply to the properties of instruments, which may be used up during utilization like: cutting, clamping etc. The user must state the fitness of the medical instruments for a specific surgical procedure. CHIFA shall not be liable for incidental or deliberate damages of any kind caused by its instruments, including those, which were modified or improved by user without prior CHIFA agreement.
The warranty becomes void if repairs are performed by someone else than the authorized CHIFA service personnel.*

Service and Repair

Authorized CHIFA Service
ul. Tysiąclecia 14
64-300 Nowy Tomyśl

Please state the number of the invoice for the purchased instruments and provide a written description of the problem.

We are keen interested in extending the number of our customers and penetration of new markets. In case you are interested in distributing CHIFA products, please contact us at above mentioned numbers and we will be happy to provide you with all necessary information concerning the possibility and conditions of cooperation, which I hope turn out to be fruitful for both sides.

BONE RONGEURS

upper part of jaw movable



upper part of jaw movable

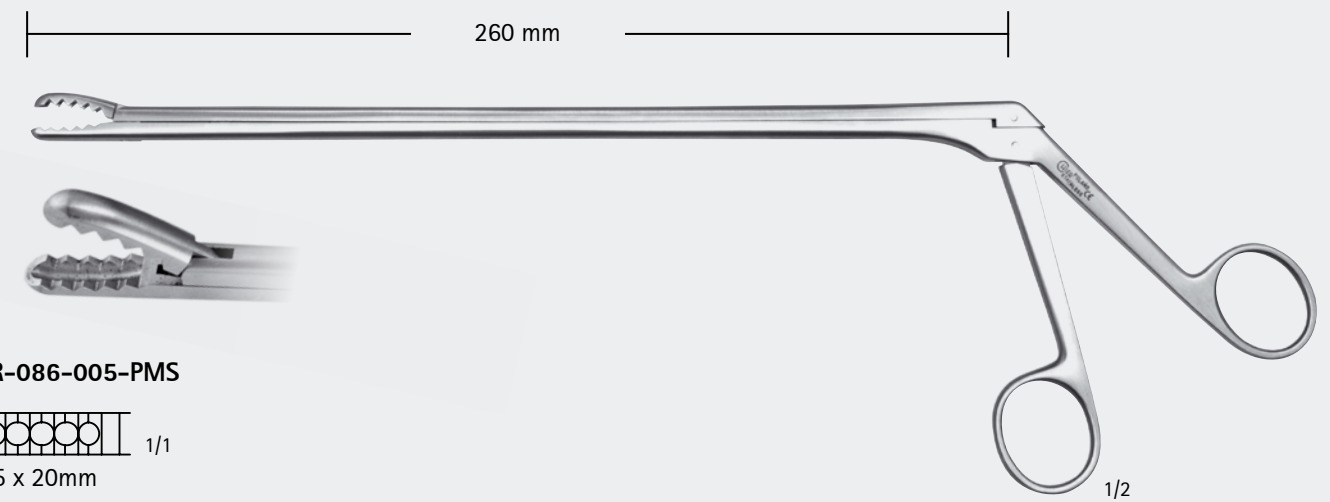

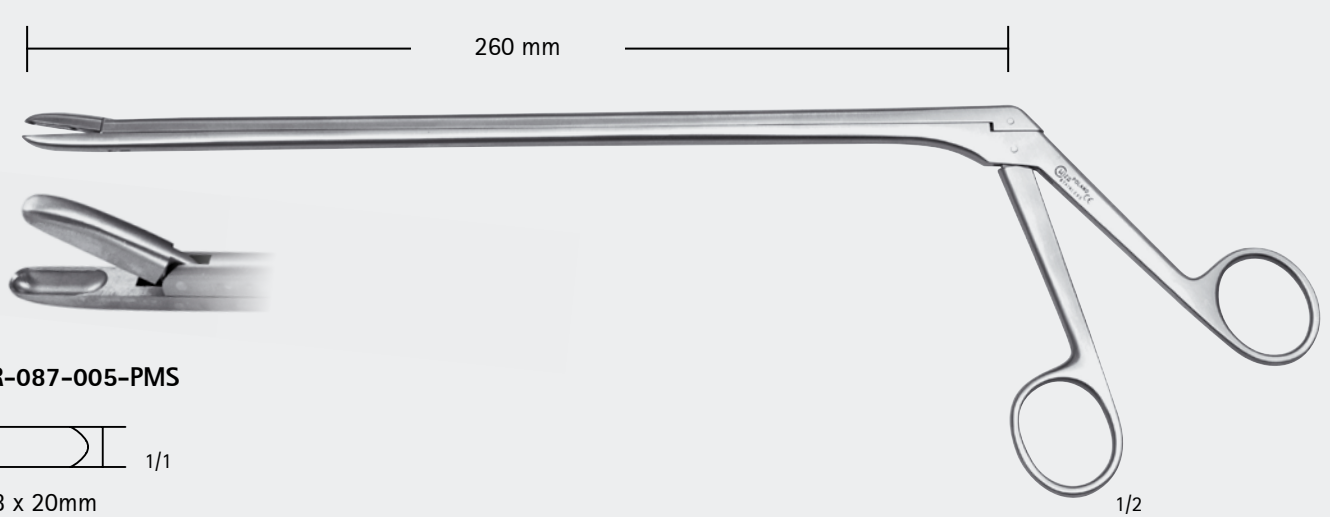

upper part of jaw movable

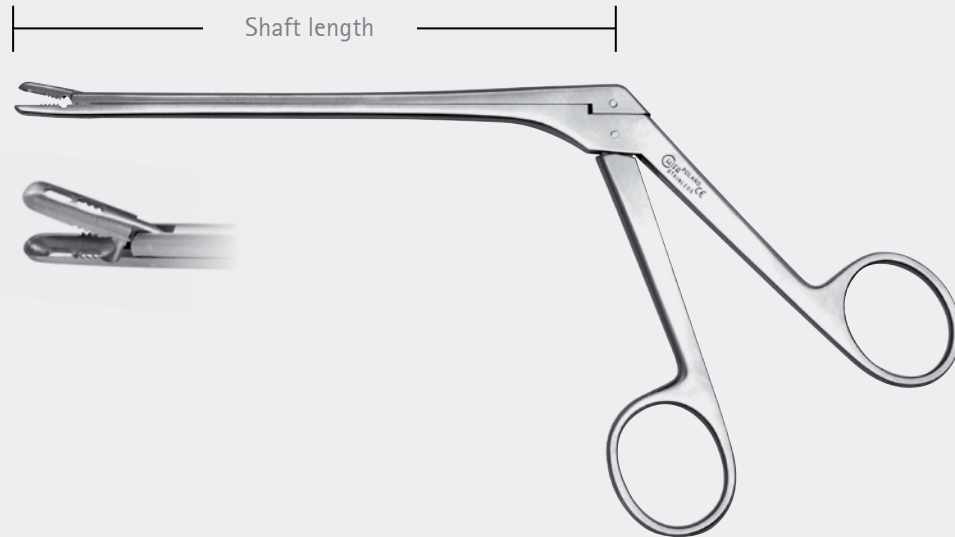

upper part of jaw movable

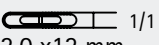
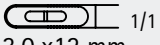

CASPAR

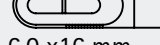

Shaft length	Jaw size				
	 1/1 2,0 x 12 mm	 1/1 3,0 x 12 mm	 1/1 4,0 x 14 mm	 1/1 5,0 x 14 mm	 1/1 6,0 x 16 mm
140 mm	KR-502-002-PMS	KR-503-003-PMS	KR-504-004-PMS		
160mm	KR-532-002-PMS	KR-533-003-PMS	KR-534-004-PMS	KR-535-005-PMS	KR-536-006-PMS
185 mm	KR-562-002-PMS	KR-563-003-PMS	KR-564-004-PMS	KR-565-005-PMS	KR-566-006-PMS

150°

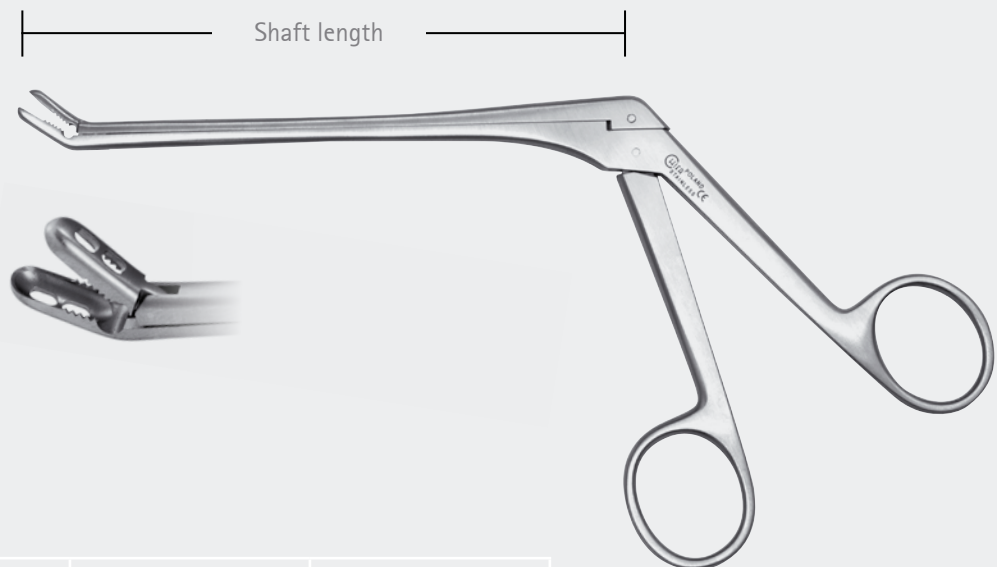
upper part of jaw movable



CASPAR



Shaft length	Jaw size		
	 1/1 3,0 x 12 mm	 1/1 4,0 x 14 mm	 1/1 5,0 x 14 mm
140 mm	KR-513-003-PMS	KR-514-004-PMS	
160mm	KR-543-003-PMS	KR-544-004-PMS	KR-545-005-PMS
185 mm	KR-573-003-PMS	KR-574-004-PMS	KR-575-005-PMS

150°

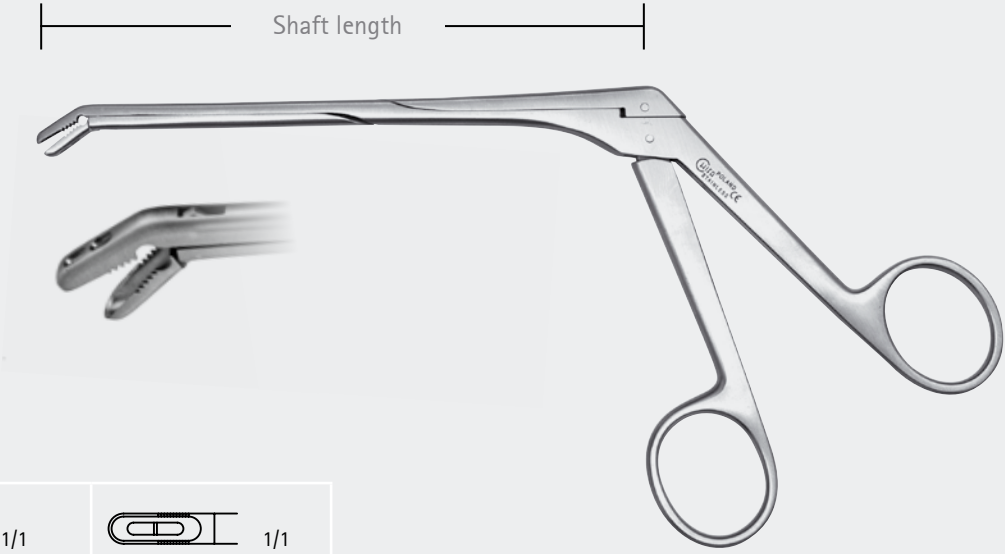
lower part of jaw movable



CASPAR

Shaft length	Jaw size	
	 1/1 3,0 x12 mm	 1/1 4,0 x14 mm
140 mm	KR-523-003-PMS	KR-524-004-PMS
160mm	KR-553-003-PMS	KR-554-004-PMS
185 mm	KR-583-003-PMS	KR-584-004-PMS

upper part of jaw movable

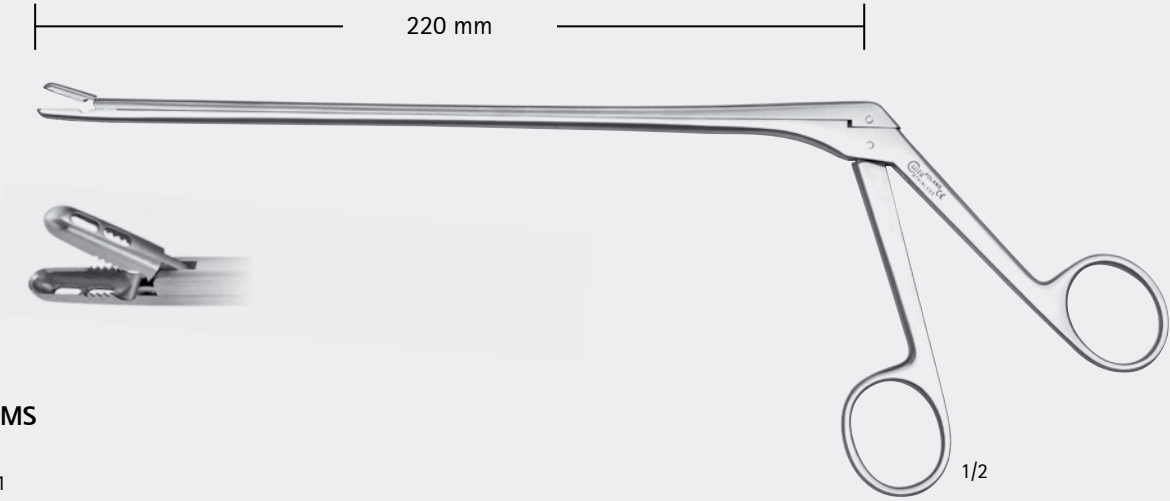

CASPAR

KR-569-004-PMS

 1/1
4,0 x 14 mm

KR-571-006-PMS

 1/1
6,0 x 16 mm

upper part of jaw movable

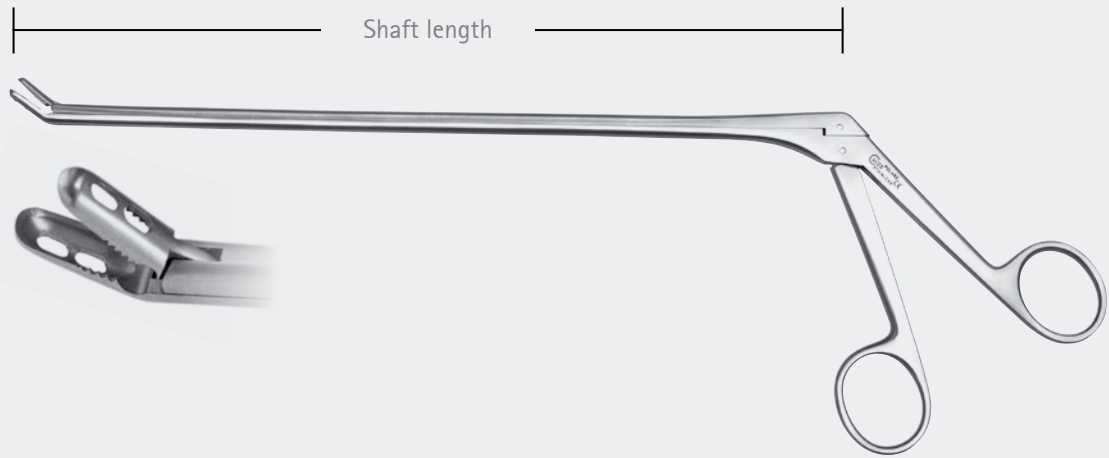

CASPAR

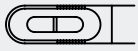
	 1/1
Shaft length	5,0 x 14 mm
220 mm	KR-578-005-PMS
250 mm	KR-579-005-PMS

lower part of jaw movable

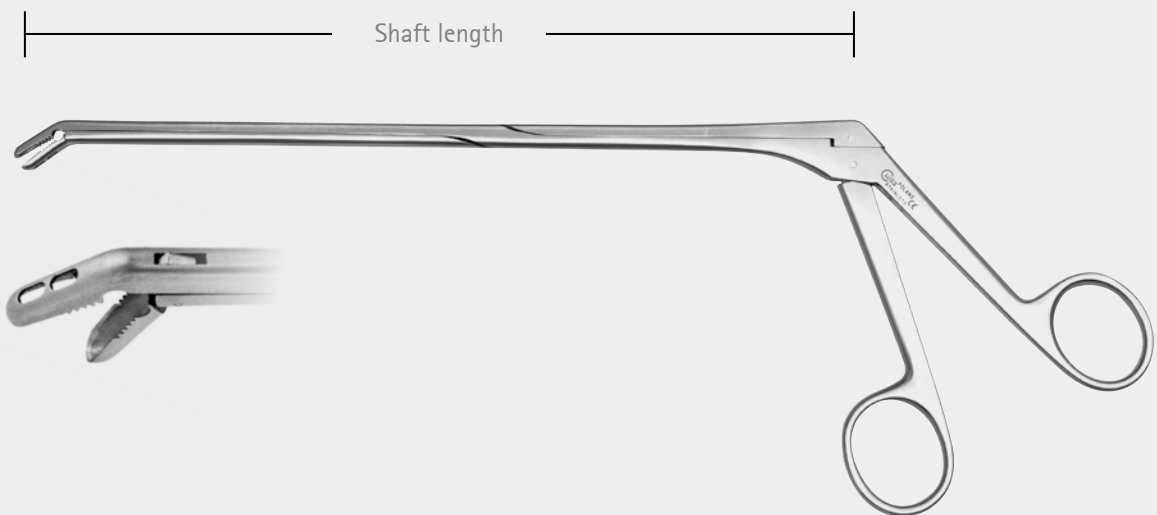

CASPAR

	 1/1
Shaft length	4,0 x 14 mm
220 mm	KR-586-004-PMS
250 mm	KR-587-004-PMS

upper part of jaw movable

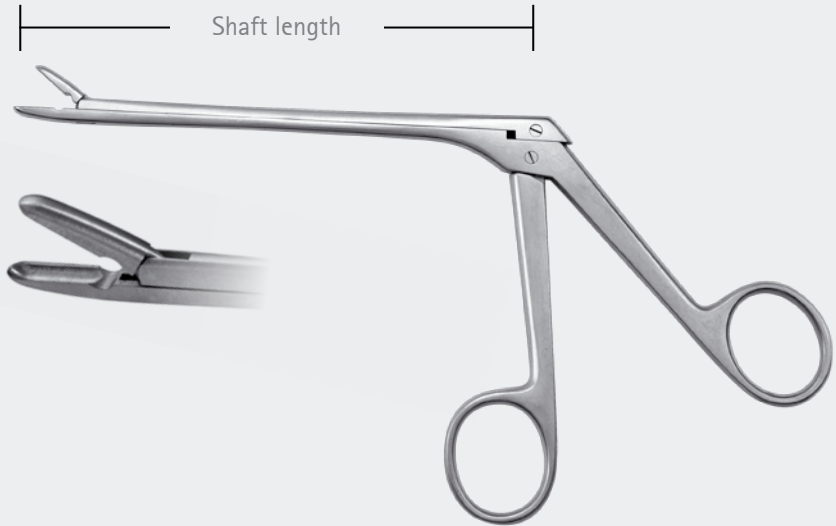

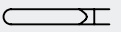
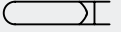
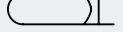

Shaft length	Jaw size		
	 1/1 2,0 x10 mm	 1/1 3,0 x10 mm	 1/1 4,0 x10 mm
135 mm	KR-799-002-PMS LOVE-GRUENWALD	KR-800-003-PMS LOVE-GRUENWALD	
130mm			KR-801-004-PMS SPURLING

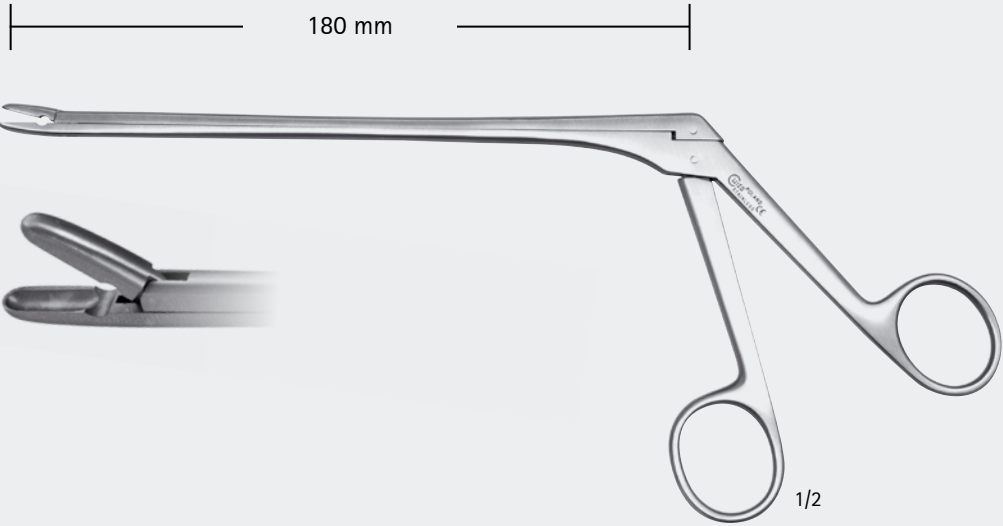
upper part of jaw movable

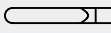

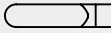
 1/1
KR-803-002-PMS
CUSHING
2,0 x 10 mm

 1/1
KR-805-003-PMS
LOVE-GRUENWALD
3,0 x 10 mm

 1/1
KR-807-004-PMS
SPURLING
4,0 x 10 mm

upper part of jaw movable

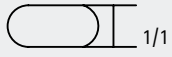

KR-808-005-PMS
5,5 mm

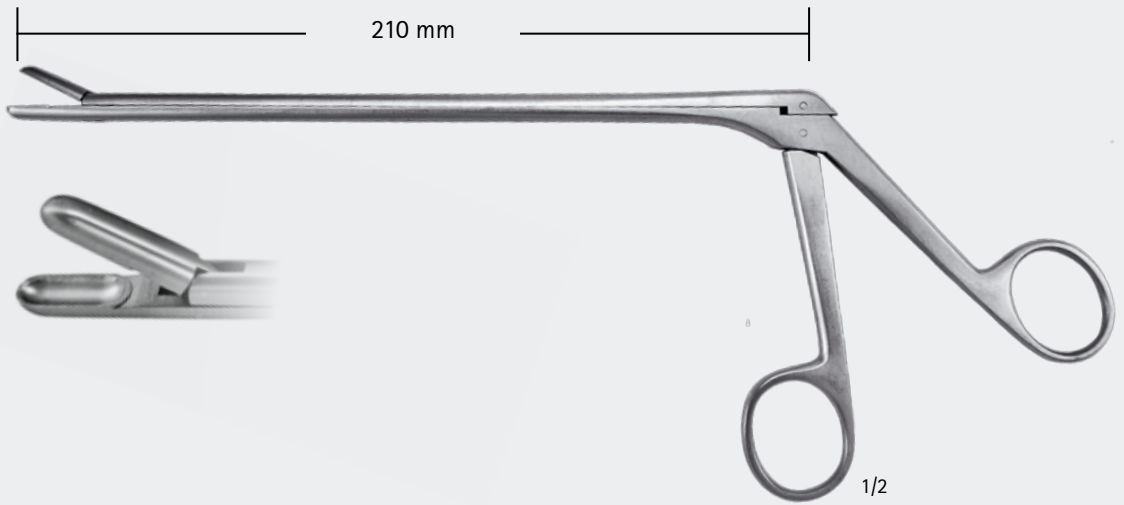

WAGNER

150°

lower part of jaw movable

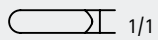

KR-810-003-PMS
3,0 x 10 mm

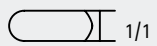

KR-811-004-PMS
4,0 x 10 mm

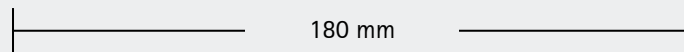

LOVE-GRUENWALD

150°

upper part of jaw movable

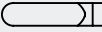
 1/1
KR-806-003-PMS
 3,0 x 10 mm

 1/1
KR-814-004-PMS
 4,0 x 10 mm

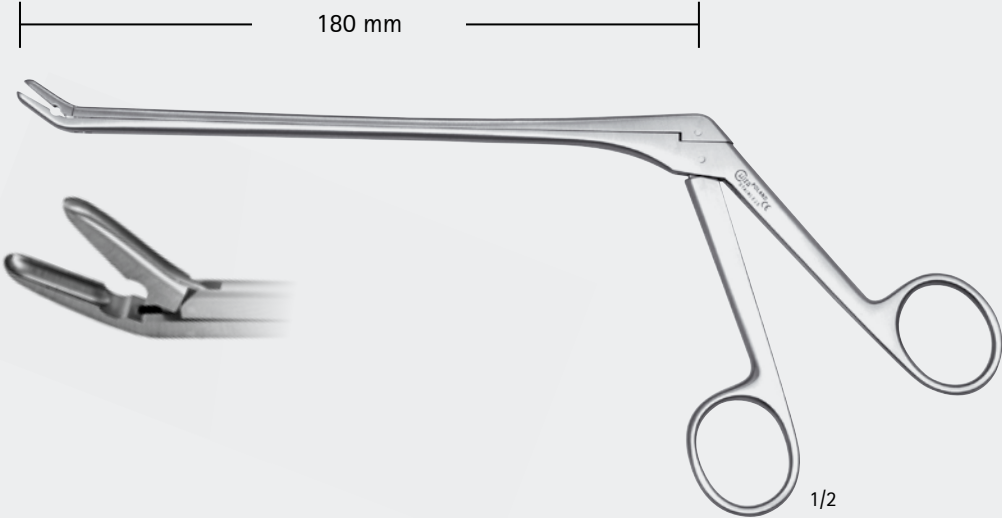

LOVE-GRUENWALD

upper part of jaw movable

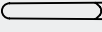
 1/1
KR-832-002-PMS
 2,0 mm

 1/1
KR-833-003-PMS
 3,0 mm

 1/1
KR-834-004-PMS
 4,0 mm

 1/1
KR-835-005-PMS
 5,0 mm

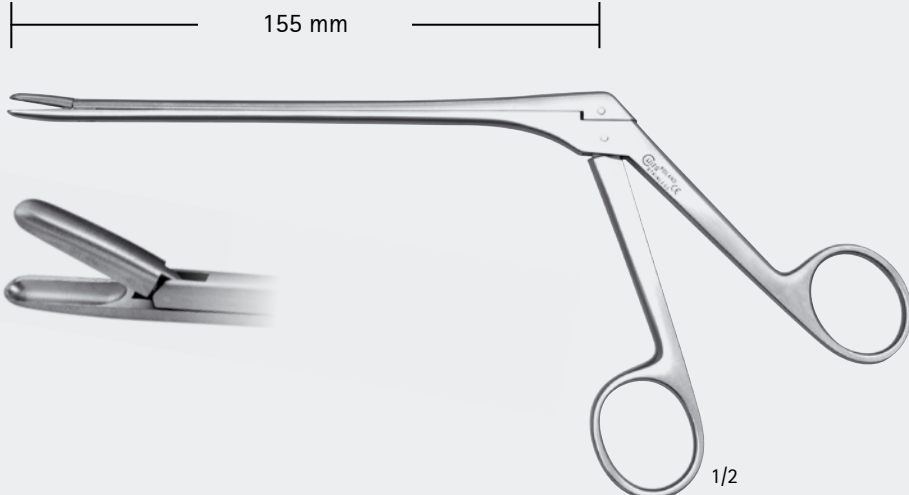

CASPAR

150°

upper part of jaw movable

 1/1
KR-842-002-PMS
2,0 mm

 1/1
KR-843-003-PMS
3,0 mm

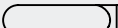
 1/1
KR-844-004-PMS
4,0 mm

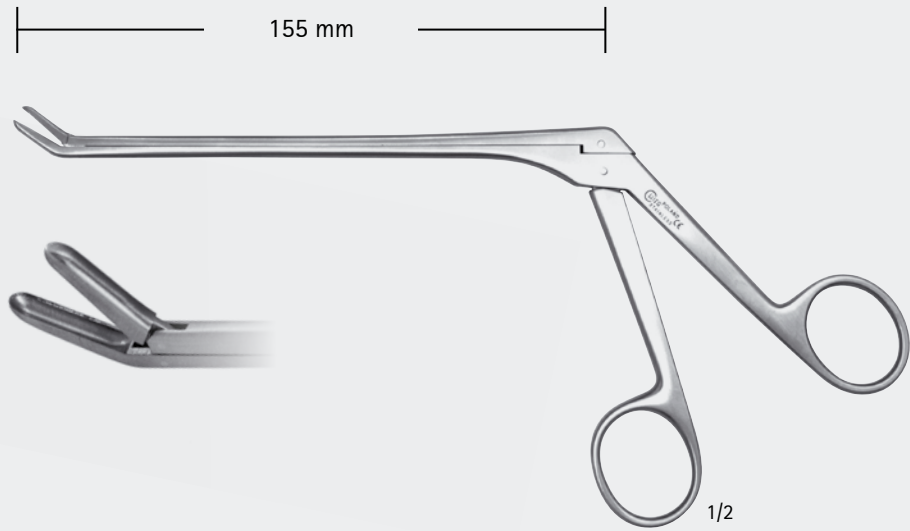

CASPAR

150°

lower part of jaw movable

 1/1
KR-852-002-PMS
2,0 mm

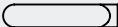
 1/1
KR-853-003-PMS
3,0 mm

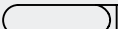
 1/1
KR-854-004-PMS
4,0 mm

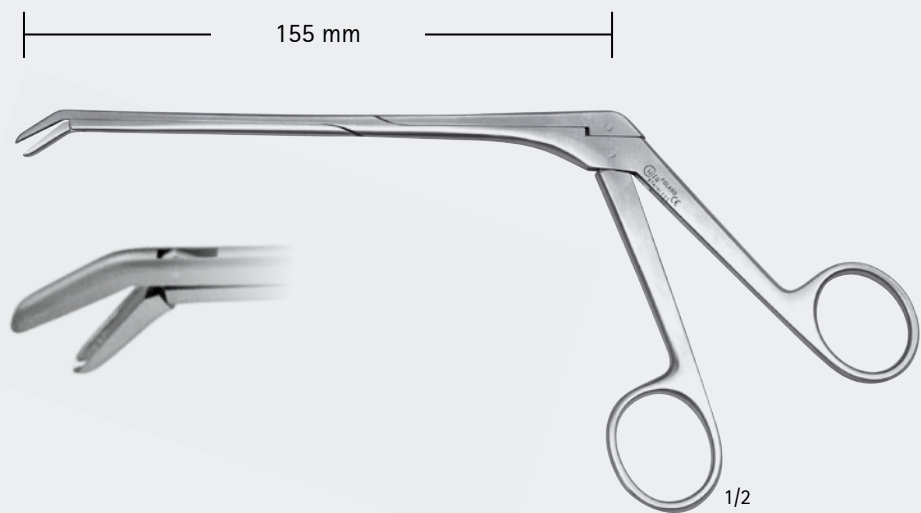

CASPAR

KR-057-005-PMS	1	KR-569-004-PMS	3	KR-835-005-PMS	7
KR-086-005-PMS	1	KR-571-006-PMS	3	KR-842-002-PMS	8
KR-087-005-PMS	1	KR-573-003-PMS	2	KR-843-003-PMS	8
KR-502-002-PMS	2	KR-574-004-PMS	2	KR-844-004-PMS	8
KR-503-003-PMS	2	KR-575-005-PMS	2	KR-852-002-PMS	8
KR-504-004-PMS	2	KR-578-005-PMS	4	KR-853-003-PMS	8
KR-513-003-PMS	2	KR-579-005-PMS	4	KR-854-004-PMS	8
KR-514-004-PMS	2	KR-583-003-PMS	3		
KR-523-003-PMS	3	KR-584-004-PMS	3		
KR-524-004-PMS	3	KR-586-004-PMS	4		
KR-532-002-PMS	2	KR-587-004-PMS	4		
KR-533-003-PMS	2	KR-799-002-PMS	5		
KR-534-004-PMS	2	KR-800-003-PMS	5		
KR-535-005-PMS	2	KR-801-004-PMS	5		
KR-536-006-PMS	2	KR-803-002-PMS	5		
KR-543-003-PMS	2	KR-805-003-PMS	5		
KR-544-004-PMS	2	KR-806-003-PMS	7		
KR-545-005-PMS	2	KR-807-004-PMS	5		
KR-553-003-PMS	3	KR-808-005-PMS	6		
KR-554-004-PMS	3	KR-810-003-PMS	6		
KR-562-002-PMS	2	KR-811-004-PMS	6		
KR-563-003-PMS	2	KR-814-004-PMS	7		
KR-564-004-PMS	2	KR-832-002-PMS	7		
KR-565-005-PMS	2	KR-833-003-PMS	7		
KR-566-006-PMS	2	KR-834-004-PMS	7		

CHIFA Sp. z o.o.
ul. Tysiąclecia 14
64-300 Nowy Tomyśl, Poland

tel. +48 61 44 20 260
fax. +48 61 44 20 261

info@chifa-oem.pl
www.chifa-oem.pl